

# Some T.1154 Modifications

FOR BETTER PHONE  
QUALITY AND IMPROVED  
AERIAL COUPLING

J. V. HOBAN (G3EGC)

*The T.1154, still in good supply at a reasonable price, can be looked upon as one way of acquiring, cheaply, a "band-switched table topper"—for the T.1154 takes in two amateur bands, 3.5 and 7 mc, as it stands. It can be run at up to 100-120 watts input on CW, and also on phone, though at reduced power. But it is true to say that modifications are called for if results up to the best amateur standard are to be obtained. This article discusses, in particular, the problem of cleaning up the modulation, and also describes some useful alterations on the RF side. Previous articles on the T.1154 appeared in our issues of October, 1946, and December, 1953.—Editor.*

“GIVE a dog a bad name.” This is evidently what has happened to the T.1154, judging by the remarks heard over the air from many stations. It is true that used in their original condition, they are rough, to say the least, but the writer has achieved a very satisfying degree of success with his T.1154. Numerous requests for details of the modifications involved have inspired the writing of this article, in the hope that the information may be of value to those who have acquired an 1154 and don't quite know what to do with it.

## Power Supplies

It is customary for this part of any article to come towards the end—but in connection with the T.1154 it is necessary to lay special emphasis on two points concerning power supplies. First, the transmitter was designed to operate with 1200v. For satisfactory results at least 900v. is necessary. Attempts to get good results on a mere 500v. or so will prove disappointing, as the writer's experience has shown. Secondly, an LT supply of 6v. DC is used in these modifications. This is obtained from a battery on trickle-charge which serves the heaters and also the relays. While it is possible to operate the T.1154 on 6v. AC, the writer has not tried this and so cannot offer any comments.

## RF Modifications

Attention was first turned to the PA stage. The panel carrying the PA tank circuits was removed after all necessary disconnections had been made and the 200-500 kc PA coil was discarded as being obviously useless for amateur band work.

Next, all the tapings on the two remaining coils were taken off, leaving the coils stripped clean. As it was proposed to use the transmitter on 80 metres only, a 3-turn shielded link-coupling coil was constructed, placed at the earthy end of the 3.5 mc coil and brought out to a coax plug on the panel. The panel was then replaced and the tank circuits wired up.

The 20,000-ohm grid resistor on the PT15's (the PA valves) was now disconnected and an RF choke wired in between this resistor and the PT15 grids. On the other side of this resistor and the HT line was inserted a 5 mA grid current meter, suitably decoupled. This was placed in the position occupied by the original "Mag Feed" (or plate current) meter. The aerial current meter was removed and the plate current meter mounted in that position and rewired. (The grid current meter is merely a useful refinement and can be omitted if not thought necessary).

## Aerial Tuning Unit

It was proposed to end-feed a long-wire aerial and so an orthodox aerial tuning unit was constructed consisting of a suitable coil and condenser coupled to the transmitter through a coupling coil similar to the one placed round the tank coil. The coil and condenser actually used were taken from a TU6B tuning unit, but a condenser of approx. 100  $\mu\text{F}$  will do just as well. The coil is of 30 turns wound 10 turns per inch with 16 SWG tinned copper wire on a 2 in. diameter former.

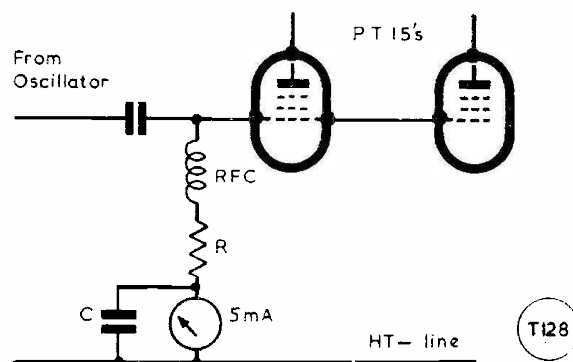

Fig. 1. The grid side of the parallel-PT15's PA, as modified by G3EGC; C is .01  $\mu\text{F}$ , and R 20,000 ohms. The RF choke and grid meter are additional items and the modification as a whole results in a worth-while improvement on the RF side.

An aerial cut exactly to length (132 ft.) will load up when connected to the top of this circuit. In the writer's case, the aerial is somewhat longer and it was found necessary to tap down the coil a little way. By using a suitable relay, the receiver can be fed from the unit and earthed on "send." The whole aerial unit was built into a TU case and the coupling coil brought out to a coax plug on the front panel. The unit is now connected to the T.1154 through a short length of 80-ohm coax cable and the whole system is thoroughly earthed. (The writer uses the water main.) Before the rig will work, it is necessary to short out a 5,000-ohm resistor which is in the HT-line. This biases off the PA and oscillator for CW working and is normally shorted out by the relay when on "send." The wiring to this resistor was removed from the relay and brought out to a jack fitted with a shorting contact to earth. By keying across this resistor, a T9 note was obtained.

**Operation**

The aerial tuning unit condenser is set to

**Table of Values**

Fig. 3 Circuit of Speech Amplifier for T.1154

C1 = 50 $\mu$ F	R5 = 10,000 ohms
C2, C7 = 50 $\mu$ F	R7, R11 = 470,000 ohms
C10 = 50 $\mu$ F	R8 = 5,000 ohms
C3, C8 = 8 $\mu$ F	R10 = 165,000 ohms 5w. (for 900v. HT);
C4, C5, C9 = 0.1 $\mu$ F	190,000 ohms. 5w. (for 1350v. HT).
C6 = .002 $\mu$ F	R12 = 820 ohms as fitted
R1 = 5 megohm	V1, V2 = 6SJ7 metal
R2 = 1,000 ohms	V3 = ML6 (as fitted)
R3, R6 = 100,000 ohms	
R4 = 500,000 ohms	

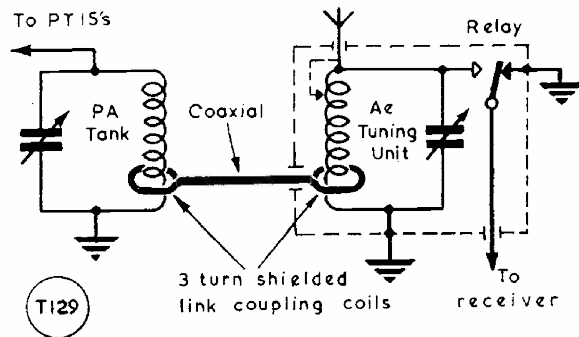

Fig. 2. In the original, the T.1154 is intended for a direct aerial connection. Better results are obtained with a separate tuning unit, enabling the PA to be properly loaded and the aerial correctly resonated. This sketch shows the arrangement used by G3EGC.

minimum capacity and the transmitter is switched on. The PA tuning condenser is adjusted for dip and the aerial unit is tuned until maximum plate current is drawn. The writer tunes against a field strength meter and finer adjustments can be made this way. With 900v. the T.1154 will draw about 50 mA.

**Modulation**

This is the feature of the T.1154 which is most criticised, and, when operated in the original condition, quite deservedly so. Suppressor grid modulation is employed and a moving coil or carbon microphone can be used. The quality is "rough" whichever it is, but can be cleaned up quite simply. In the writer's case the method was as follows: A 50  $\mu$ F electrolytic condenser was wired in across the cathode resistor (820 ohms) of the ML6 modu-

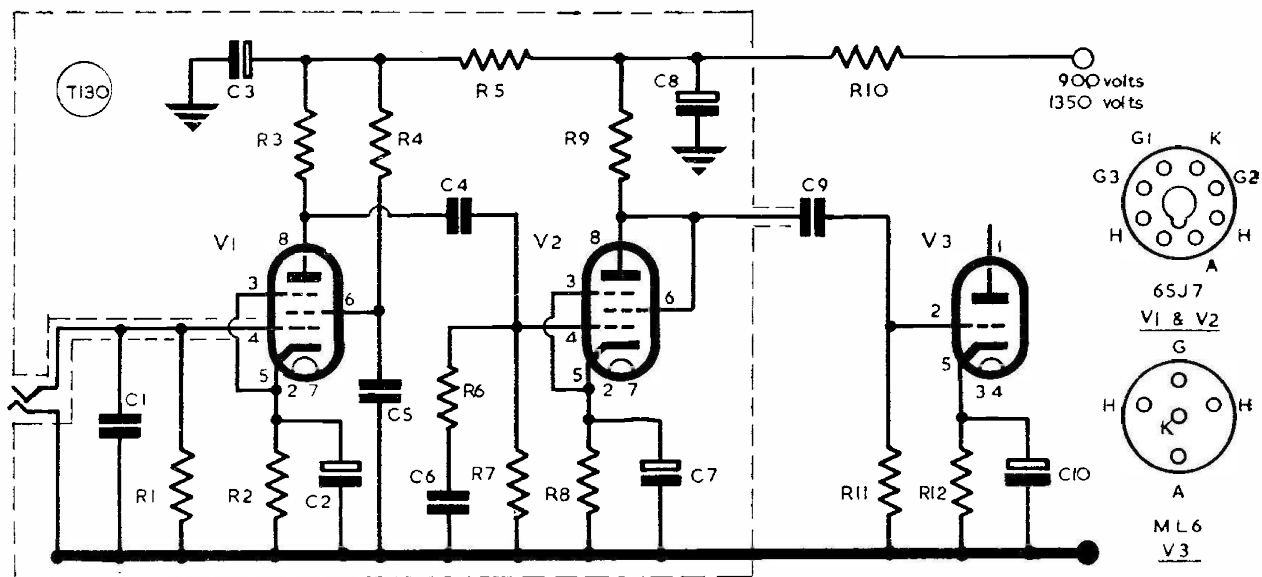

Fig. 3. Circuit of the two-valve speech amplifier incorporated in his T.1154 modulator circuit by G3EGC. V1, V2, are the new stages, for which values are given in the table, and V3 is the ML6 modulator as fitted in the original. The results on phone are greatly improved by this modification.

lator valve; a 100  $\mu$ F electrolytic condenser was put across the 2  $\mu$ F condenser which decouples the microphone transformer. (This can be found above the two ML6's.) Using a GPO type carbon microphone, quality reports which can be described as "quite good" were received.

Incidentally, the energising voltage for the carbon microphone is obtained from the vitreous enamelled resistor which can be seen when the front panel is removed. This is connected between earth and the 6v. LT line. Any attempt to use AC instead of DC will put an AC voltage on the speech circuit and so some alternative means of energising will be required.

This system of modulation was used for some time, but the modulation level was low and so it was decided to improve matters. A small deaf-aid crystal insert was obtained and after preliminary experiments, a 2-valve pre-amplifier was built and coupled into the ML6. Immediately, quality reports improved, the most frequent comment being "very pleasant to listen to," and the modulation was full. The pre-amplifier was built into a small metal box and metal type valves were used. The box was fitted in the space left by the 200-500 kc PA coil. No feed-back from the PA stage is

experienced. The arrangement is still in use and is giving every satisfaction. The final modulation circuit is shown in Fig. 3.

In all the modulation experiments both the carbon and crystal inserts were employed in the manner described by G5WW in his article on "Carbon Microphones" in the March, 1951, issue of *Short Wave Magazine*.

The T.1154 has been in use now for over five months, giving entire satisfaction. The whole of the U.K. has been worked, together with EI, PA, OZ, DL2, DL4, and so on, all on phone. The most recent development has been an increase in power. A new power unit was built and there is now 1350v. on the transmitter, giving an input of 100 watts. The only change necessary was to alter the modulator dropping resistor (R10) from 165,000 ohms to 190,000 ohms.

All these modifications have been carried out on the T.1154 *Type B*, but it is thought that the other makes can be similarly modified.

Practical proof of the fine job this transmitter is doing can be obtained by listening on 80 metres most Saturdays and Sundays, when phone from G3EGC may be heard. The writer will appreciate any reports on his transmissions—and you can be as critical as you like!

## Modulation with the Receiver

USING THE OUTPUT STAGE  
FOR QRP PHONE

N. P. SPOONER (G2NS)

NOT every amateur takes full advantage of the many facilities and possible modifications afforded by a good receiver. By this is meant, of course, the genuine article, not the ordinary short-wave broadcast type simply fitted with a BFO, under the delusion that this addition at once elevates the entire assembly into the "communications" class. Neither can the proud title be truthfully claimed by surplus receiving equipment specifically designed for non-amateur use and band-coverage.

Of the popular models now in circulation on the amateur bands—to mention some points of interest concerning only five—does the station change-over include relay switching of the HT to the *HRO* and how many output

valves have been ruined by headphone receptionists who forgot to complete the plate circuit with a jumper, or add a load in the absence of a built-in output transformer? Is negative bias being applied to the diversity reception terminal of the *AR88* to provide BK muting, and is the "Send-Receive" switch being employed as a one-knob change-over control for the entire station? Are the 5000-ohm output terminals of the *SX28* being used to feed directly into a tape recorder, and are the advantages of single-signal adjustment, tone, bass and selectivity control settings being fully realised during CW reception? Has the oscillator HT of the *S640* been stabilised, and has the 40 mA drain (more than the entire load for the rest of the set) of the 6V6 output stage been cut by substituting a 6J5 (500 milliwatts)? Are the aerial-earth terminals of the *S750* being shorted across by relay for stand-by protection, and are the two output stages being used as a modulator?

### The Modulator Possibility

This latter thought should certainly interest brass-pounders who want no expense and the minimum of extra gear for local-net telephony.